



FONTE SLIM 36A

FONTE 100A

FONTE SLIM 50A

FONTE 120A

FONTE SLIM 60A

FONTE 150A

FONTE 70A

FONTE 200A

USER MANUAL

PRESENTATION

The Charging Supplies 36A, 50A, 60A, 70A, 100A, 120A, 150A and 200A are high power power supplies that enable powering and charging automotive battery(s), providing a maximum current of 36A at the output, respectively, 50A, 60A, 70A, 100A, 120A, 150A and 200A and operate in two modes: 14.4V or Auto SCI.

Auto SCI (Intelligent Charging System) function increases the efficiency of battery charge accumulation, prolonging its useful life.

The 36A, 50A, 60A, 70A, 100A, 120A, 150A and 200A Charging Supplies have a digital display to monitor voltage or current or accumulated charge and battery level and full charge indicator LEDs.

TYPES OF READINGS

Voltage: Informs the voltage sent to the system.

Current: Shows the current consumed by the system.

Ampere Hour Counter: Informs how much charge has been accumulated by the battery during the charging cycle, with this reading it is possible to know if the battery is in good working order.

The counter can be reset by holding the Read key for 5 seconds. When it reaches 999 it must be reset to continue reading the accumulated battery charge.

OPERATING MODES

14.4V: Keep the power supply operating with the output voltage at 14.4V.

Auto SCI: Allows the power supply output to operate at 14.4V when the system requires more power. In fluctuation it operates with the output voltage in cycles of 13.8V for 5 minutes and 14.4V for 10 seconds. This system prevents the excessive rise of the potential of the plates, a chemical phenomenon caused by load stress, which reduces the useful life and efficiency of the batteries.

IMPORTANT TIPS

1- Whenever using the sound, charge the batteries until the Source's charge indicator shows full charge. This means the batteries will be 100% charged. The charging process does not damage the batteries, as when they are fully charged, the Sources go into float mode.

2- We advise that when using the sound, turn on the Source immediately. Don't wait for the batteries to discharge before doing this.

3- Use 1 outlet per equipment. Each 36A, 50A, 60A, 70A, 100A, 120A, 150A and 200A Power Supply consumes about 480W, 750W, 900W, 1100W, 1500W, 1800W, 2250W and 3000W from the power grid respectively.

4- Use 6mm² cable at the 36A output, 8mm² at the 50A output, 10mm² at the 60A output, 25mm² at the 70A output, 35mm² at the 100A and 120A output, 50mm² at the 150A output and 70mm² at the 200A output.

5- Do not install in high vibration environments such as speakers.

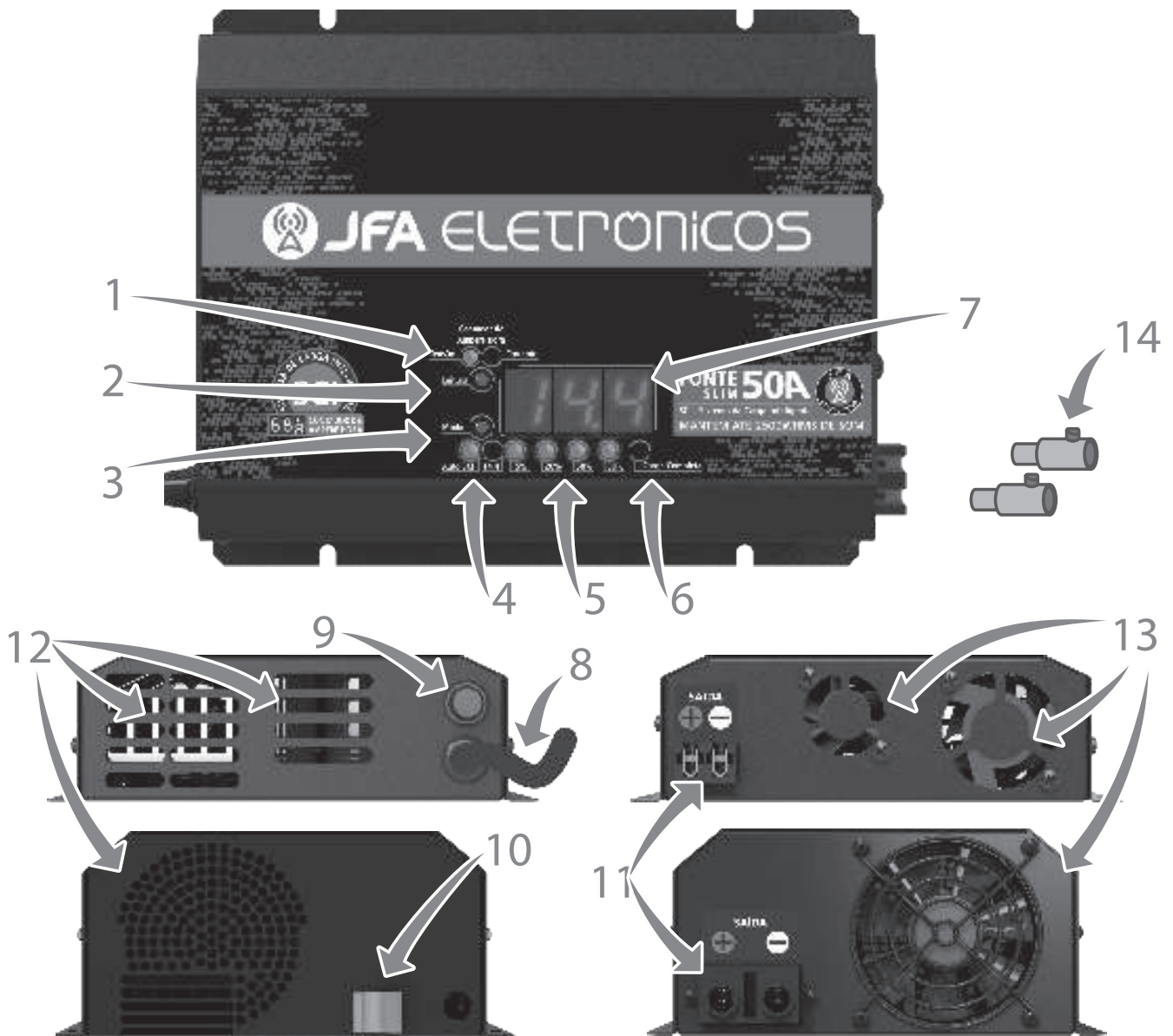

DESCRIPTIONS

- 1 - Leds that indicate the monitoring of Voltage or Current or Ampere Hour Counter "2 leds on";
- 2 - Voltage or Current reading mode selector switch or Ampere Hour Counter;
- 3 - 14.4V or Auto SCI voltage mode selector switch;
- 4 - Leds indicating voltage 14.4V or Auto SCI;
- 5 - Battery charge indicator LEDs;
- 6 - Led indicator of full charge;
- 7 - Voltage or Current indicator display or Ampere Hour Counter;
- 8 - Power input tail;
- 9 - 15A input fuse (36A slim and 50A slim models);
- 10 - Circuit breaker acting as an on/off switch (70A, 100A, 120A, 150A and 200A models);
- 11 - Output connector;
- 12 - Air outlet (never obstruct);
- 13 - Air intake (never obstruct);
- 14 - 10mm² gauge cable adapter (exclusive for 60A power supply).

CONNECTIONS DIAGRAM

Each Source 36A, 50A, 60A, 70A, 100A, 120A, 150A and 200A can power about 1800, 2500, 3000, 3500, 4400, 6000, 7000 and 10000 Wrms of sound playing respectively, provided that using a battery in parallel to meet the consumption peaks.

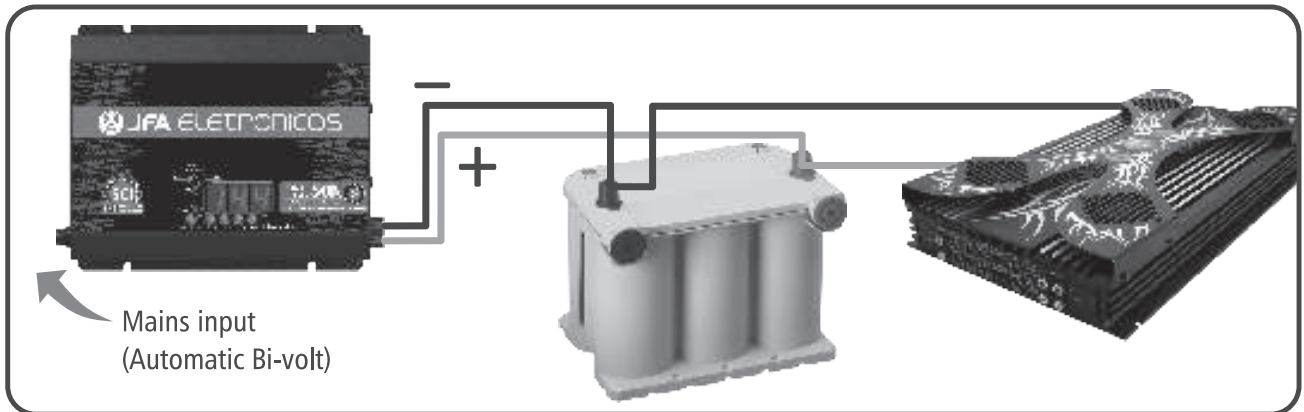

You can use as many sources 36A, 50A, 60A, 70A, 100A, 120A, 150A and 200A as needed to feed the sound, having as a reference that each one maintains about 1800, 2500, 3000, 3500, 4400, 6000, 7000 and 10000 Wrms of sound playing respectively, it is important to note that for this the operating mode must be the same for all sources that are in parallel (ex.: All in 14.4V mode or all in Auto SCI).

Main advantage: With this modular system, you can choose how many devices to connect and thus adapt it to the capacity of the electrical network. This situation happens mainly when using local power generators. This way, you will connect the amount of equipment that the generator can supply.

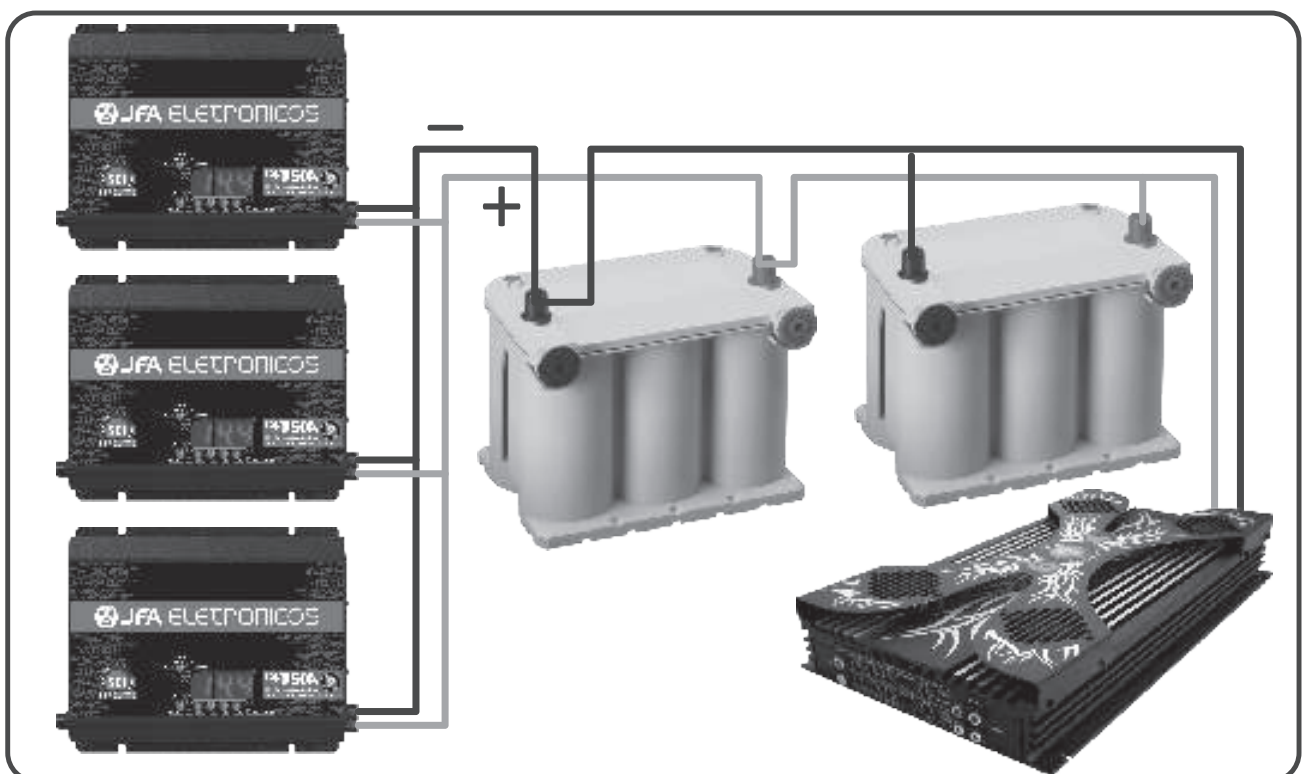

SPECIFICATIONS CHARGING SUPPLIES 36A SLIM	Input (Automatic Bi-volt)	90 to 140Vac / 170 to 240Vac
	Consumption with maximum load	480W
	Maximum output current	36 amps
	Maximum output voltage	14.4 Vdc
	Intelligent charging system	13.8 Vdc / 14.4 Vdc cyclic
	Voltmeter / Ammeter Accuracy	99% / 96%
	Refrigeration	Forced
	Protections	Overload, short output and temperature
	Dimensions W x H x D (mm)	170 x 163 x 48
	Weight kg	1,060

SPECIFICATIONS CHARGING SUPPLIES 50A SLIM	Input (Automatic Bi-volt)	90 to 140Vac / 170 to 240Vac
	Consumption with maximum load	750W
	Maximum output current	50 amps
	Maximum output voltage	14.4 Vdc
	Intelligent charging system	13.8 Vdc / 14.4 Vdc cyclic
	Voltmeter / Ammeter Accuracy	99% / 96%
	Refrigeration	Forced
	Protections	Overload, short output and temperature
	Dimensions W x H x D (mm)	195 x 163 x 48
	Weight kg	1,175

SPECIFICATIONS CHARGING SUPPLIES 60A SLIM	Input (Automatic Bi-volt)	90 to 140Vac / 170 to 240Vac
	Consumption with maximum load	900W
	Maximum output current	60 amps
	Maximum output voltage	14.4 Vdc
	Intelligent charging system	13.8 Vdc / 14.4 Vdc cyclic
	Voltmeter / Ammeter Accuracy	99% / 96%
	Refrigeration	Forced
	Protections	Overload, short output and temperature
	Dimensions W x H x D (mm)	212 x 163 x 48
	Weight kg	1,260

SPECIFICATIONS CHARGING SUPPLIES 70A	Input (Automatic Bi-volt)	90 to 140Vac / 170 to 240Vac
	Consumption with maximum load	1100W
	Maximum output current	70 amps
	Maximum output voltage	14.4 Vdc
	Intelligent charging system	13.8 Vdc / 14.4 Vdc cyclic
	Voltmeter / Ammeter Accuracy	99% / 96%
	Refrigeration	Forced
	Protections	Overload, short output and temperature
	Dimensions W x H x D (mm)	245 x 190 x 85
	Weight kg	1,800

SPECIFICATIONS CHARGING SUPPLIES 100A	Input (Automatic Bi-volt)	90 to 140Vac / 170 to 240Vac
	Consumption with maximum load	1500W
	Maximum output current	100 amps
	Maximum output voltage	14.4 Vdc
	Intelligent charging system	13.8 Vdc / 14.4 Vdc cyclic
	Voltmeter / Ammeter Accuracy	99% / 96%
	Refrigeration	Forced
	Protections	Overload, short output and temperature
	Dimensions W x H x D (mm)	245 x 190 x 85
	Weight kg	2,040

SPECIFICATIONS CHARGING SUPPLIES 120A	Input (Automatic Bi-volt)	90 to 140Vac / 170 to 240Vac
	Consumption with maximum load	1800W
	Maximum output current	120 amps
	Maximum output voltage	14.4 Vdc
	Intelligent charging system	13.8 Vdc / 14.4 Vdc cyclic
	Voltmeter / Ammeter Accuracy	99% / 96%
	Refrigeration	Forced
	Protections	Overload, short output and temperature
	Dimensions W x H x D (mm)	245 x 190 x 85
	Weight kg	2,180

SPECIFICATIONS CHARGING SUPPLIES 150A	Input (Automatic Bi-volt)	90 to 140Vac / 170 to 240Vac
	Consumption with maximum load	2250W
	Maximum output current	150 amps
	Maximum output voltage	14.4 Vdc
	Intelligent charging system	13.8 Vdc / 14.4 Vdc cyclic
	Voltmeter / Ammeter Accuracy	99% / 96%
	Refrigeration	Forced
	Protections	Overload, short output and temperature
	Dimensions W x H x D (mm)	265 x 190 x 90
	Weight kg	2,400

SPECIFICATIONS CHARGING SUPPLIES 200A	Input (Automatic Bi-volt)	90 to 140Vac / 170 to 240Vac
	Consumption with maximum load	3000W
	Maximum output current	200 amps
	Maximum output voltage	14.4 Vdc
	Intelligent charging system	13.8 Vdc / 14.4 Vdc cyclic
	Voltmeter / Ammeter Accuracy	99% / 96%
	Refrigeration	Forced
	Protections	Overload, short output and temperature
	Dimensions W x H x D (mm)	295 x 190 x 90
	Weight kg	2,750



See all products of the automotive line
on our website.

www.jfaeletronicos.com